

SHEET PILE PROTECTOR

X9-PZC-18

MATERIAL: CAST STEEL
ASTM A148 90/60
Normal foundry tolerances apply

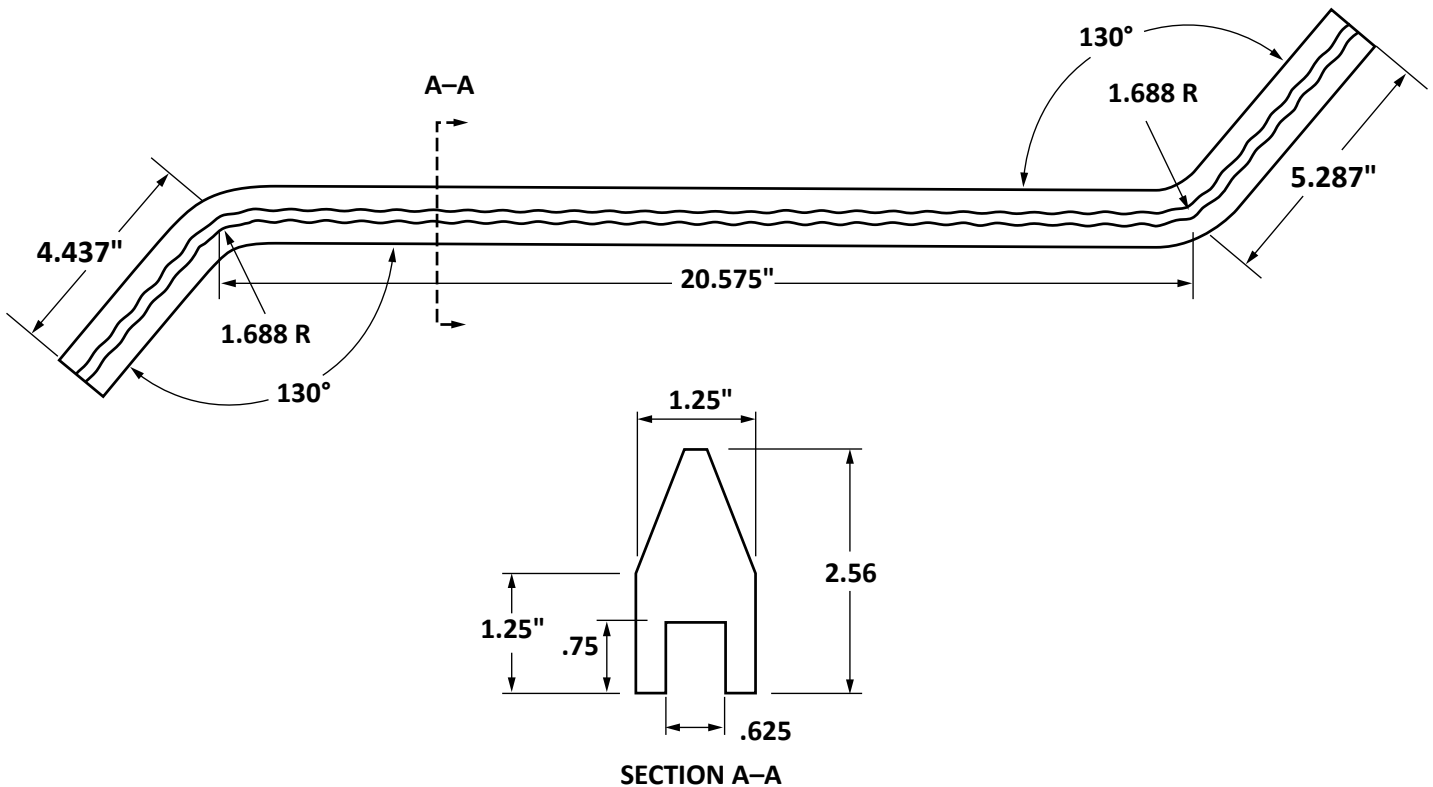

Installation Procedure

One-Piece Sheet Pile Protector

Installation procedure for the one-piece sheet pile protector for permanent sheet piles, is as follows

1. Hold the protector in close contact with end of the sheet pile.
2. Place a 3" long fillet weld, 5/16" thick, at each corner of the protector for a total of 12".

Note: An E-7018 welding rod is recommended



**ASSOCIATED PILE
& FITTING**

45 Samworth Road, Clifton, NJ 07014
Tel: 973-773-8400
Fax: 973-773-8442
email: apf@associatedpile.com
www.associatedpile.com
Call Toll Free: 800-526-9047